

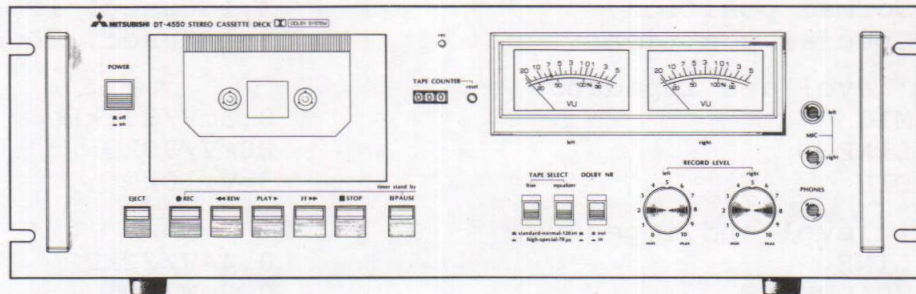

SERVICE MANUAL  
**STEREO CASSETTE DECK**  
**MODEL DT-4550, DT-4550S**

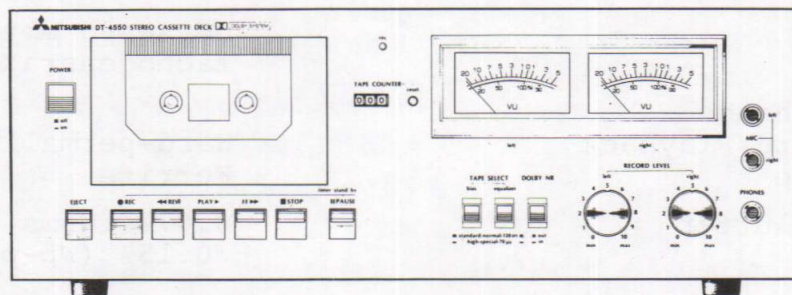

DT-4550



DT-4550S

CONTENTS	
SPECIFICATIONS .....	2
PERFORMANCE .....	3
CHARACTERISTICS TABLE.....	4
SERVICING NOTES .....	5
DISASSEMBLING OF COMPONENT PARTS .....	6
ADJUSTMENT OF THE MECHANICAL UNIT .....	21
ELECTRICAL ADJUSTMENT .....	23
PRINTED CIRCUIT BOARD .....	29
WIRING .....	31
CIRCUIT DIAGRAM .....	33
EXPLODED DIAGRAM OF CABINET .....	35
PARTS LIST .....	36
EXPLODED DIAGRAM OF MECHANICAL PARTS .....	38







(Note) The state in NORMAL and SPECIAL is as shown below:

Normal  bias  equalizer'

Special  bias  equalizer

Reproducing System and Overall System mean a reproduced tape and reproduction of a recorded tape respectively.

PERFORMANCE

Mechanical Part		Electrical Part			
Tape Speed	3000 Hz ± 60 Hz (Variation: within 30 Hz)	Minimum Input Level	LINE IN	-20dB (V) ± 3dB	
			MIC	-70dB (V) ± 3dB	
Wow & Flutter	0.18 rms (0.07 W rms) in Reproducing System	Reference Output Level	Reproducing System	LINE OUT -7dB (V) ± 1dB HEAD PHONE -22dB (V) ± 2dB	
FF, REW	Within 90 sec. at C-60		Overall System	LINE OUT	-7dB (V) <sup>+1</sup> <sub>-2</sub> dB
Numbers on Counter	638 ± 30 at C-90			Tape to be Used	TDK AC-511, (Special position)
End-Stop Working Time	Within 7 sec.	Level Meter Indication	Reproducing System	Meter Reading +3VU ± 1VU Tape for Confirmation MTT-150	
Pause	Within 0.2 sec. at rising-up/down time of tape speed				
Push-button Operating Force (Unit: kg)	PLAY 1.5	S/N Ratio	Reproducing System		Over 47 dB
	REC, FF, REW, STOP } 1.0		Overall System	Tape to be Used	Over 43 dB
	EJECT, PAUSE } Counter reset 0.8				TDK AC-221 (normal)
Pinch Roller Pressure	330 g ± 50 g	Bias Leak	LINE IN, MIC	Under -40 dB(V)	
Winding Torque	PLAY 40 ~ 60 g/cm				
	FF, REW 90 ~ 150 g/cm				



CHARACTERISTICS TABLE

Frequency Response

1) Reproducing System

	Tape for measurement
Normal position	MTT-116U
Special position	MTT-116K

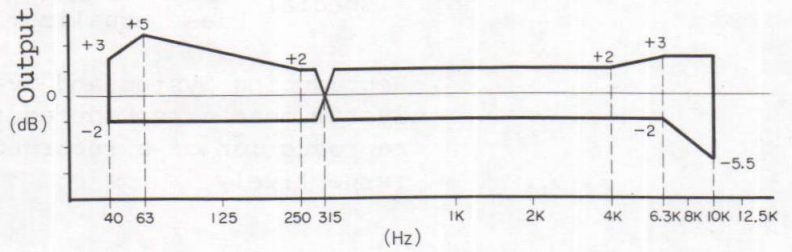

2) Overall System

	Tape for measurement
Normal position	TDK AC-221

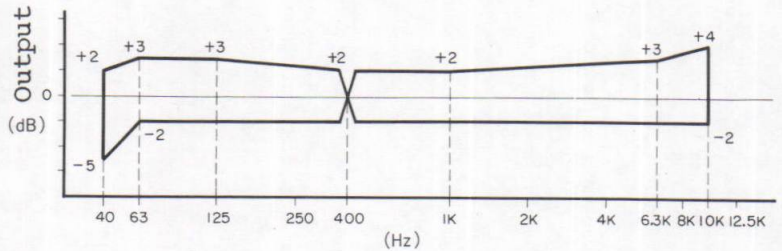

3) Overall System

	Tape for measurement
Special position	TDK AC-511

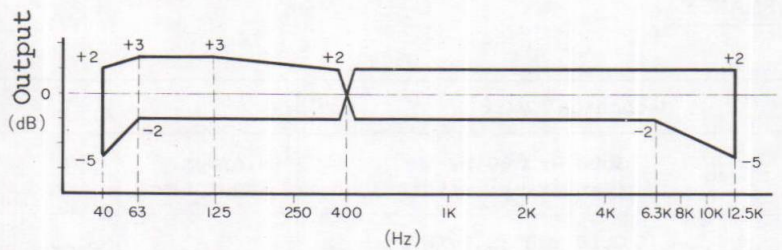

4) Overall System

	Tape for measurement
Special position	TDK AC-511

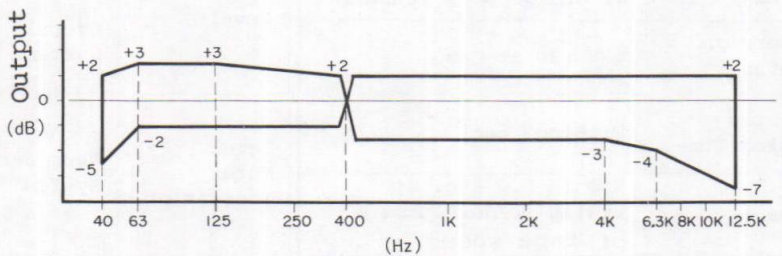

5) Monitor Output

{When a flat signal without level variation is input in the INPUT terminal.}

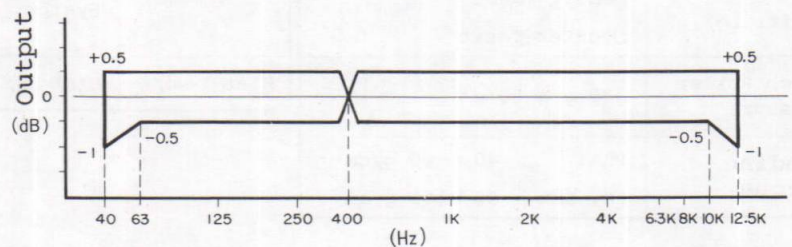



## SERVICING NOTES

1. Refer to the Instruction Manual (for operation).
2. A number of rubber parts, such as the belt and idler, are used in a tape recorder for purposes of transmitting revolution. The belt, in particular, may not be adequately durable on account of the manner of its application. Be sure to check whether it should be replaced or not at the time of servicing.
3. Unlike other audio products, the tape recorder is equipped with a mechanism. And no matter how excellent the electric circuit characteristics may be, the functions of the mechanism cannot be exploited fully unless tape transport is perfect during PLAY. Inadequate adjustments related to the tape transport system may result in serious troubles, such as revolution drift, unstable tape speed and deterioration in electric circuit characteristics arising from instability of tape-head contact. In servicing, therefore, make adjustments or repairs while paying close attention to the points given below.
4. Use special care in handling the capstan and the head, as tape recorder components generally have many precision-finished portions.
5. Demagnetize each head before making adjustment with the standard tape.

Note: Use case as the REC/PLAY head is magnetized when metered with a resistance meter like tester or vacuum tube voltmeter.



6. Demagnetize the head after using metal tools near it for purposes of repair or adjustment.
7. Keep the head surface free of magnetic particles scraped off the tape and dust (use absorbent cotton or gauze impregnated with the head cleaning solution or alcohol to clean the head).
8. Be sure power supply voltage is normal (low power supply voltage leads to deterioration in reproduced sound quality because of slowed-down tape speed and increased wow and flutter and amplifier distortion)
9. Wipe off oil dregs before lubricating, and then give one to two drops of General Oil's GEMICO TL (TAPINOL #30) to the rotary shaft and apply a small amount of Toho Polymer's FL-LUBEA (white) to the sliding faces.
10. Be sure to lock securely the cover of the cassette case when the various characteristics are to be measured.
11. Clean any stain on the cabinet with a neutral detergent.

#### DISASSEMBLING OF COMPONENT PARTS

##### Precautions

- 1) Refer to the disassembling diagram at the end of this manual.
- 2) Be careful not to allow oil stick to the revolution transmission unit during disassembling. If any happens to stick, thoroughly clean it off with alcohol or the like before reassembling.



- 3) As oil or grease is applied to the removed parts, especially to mechanical parts, be careful not to let any foreign matter stick to them.
- 4) Be sure to use specified screws when assembling, as use of screws not specified may lead to cracking of shaped articles, failure to fix the parts or demolishing of the screw thread.
- 5) Avoid marring the top panel and the meters.
- 6) Put all the removed screws and knobs in a small box or the like together so as not to lose them.
- 7) As screw locking agent is used for the screws of the mechanism unit to prevent them from becoming loose, apply a drop or two of solvent like thinner when the screws of that unit are to be removed. Then making sure that the screw lock has been softened after a few minutes, unscrew them with a screw driver that fits the screw heads perfectly. (avoid letting the solvent to stick to any part using plastic as it is corrosive).
- 8) As the disassembling method is described in the order of steps to be taken from the beginning, use it as a reference.
- 9) Be sure to achieve correct reassembling by following the steps taken in reverse order.



## 1. Removing the Cabinet Cover

- 1) The upper cover comes off when screws (1) to (8) in Fig. 1 are unscrewed (use care at this time as L-shaped holder (A) also comes off).
- 2) The lower cover ((B) in Fig. 1) comes off when screws (9) to (13) are removed. (removal of this cover allows checking of the circuit on the back side of the base board).

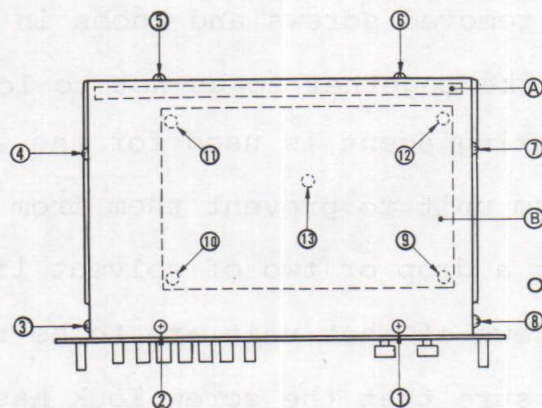

Screws (1) to (13) are of tapping type (3 x 10).

Fig. 1

## 2. Removing the Front Panel

### 1) Removing the cassette cover

Open the cover, take the cassette out, place both index fingers on the under side of the two sides of the cover and place both thumbs on the groove found on the upper side of the space housing the cassette. The cassette cover will come off when it is pushed upward with the index fingers.

### 2) Removing the knobs and the screws

Pull out the two volume control knobs.

Remove the screws on the top and under sides of the panel in Fig. 2.

Screws (1) and (2) in Fig. 2 are bind type (M3 x 0.5 x 6)

Screws (3) to (7) are tapping type (3 x 10)



3) Drawing the panel out

The panel comes off the main unit when it is pulled out. (From this condition "5. Removing the Mechanism Assembly" becomes possible).

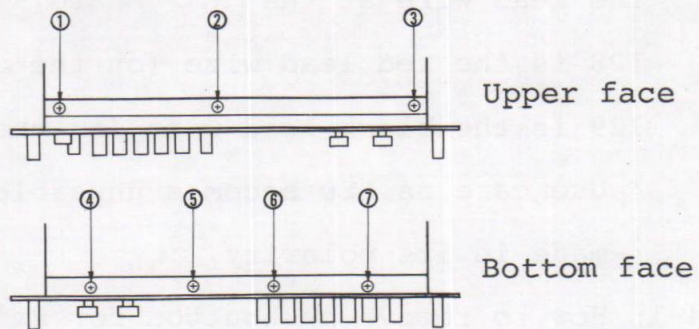

Fig. 2

3. Removing the Meter (from the panel removed in the preceding section)

Lower two places on the (C) unit of the meter holder (A) shown in Fig. 3 in the direction of the arrow and sort of push meter holder (B) upward. Then meter holder (B) will come off the meter holder (A) and the meter can be removed.

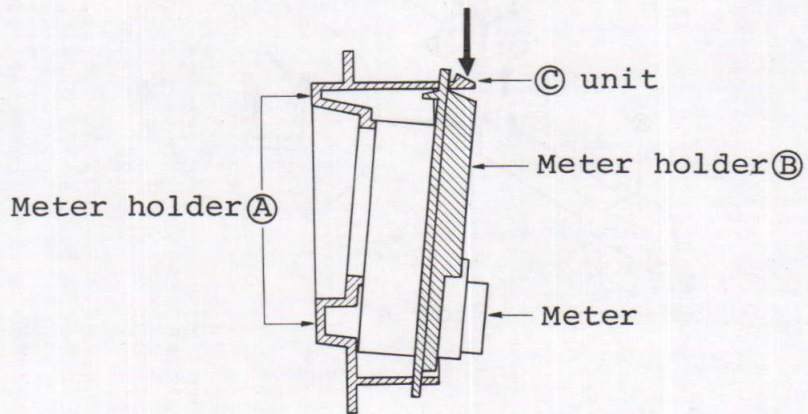

Fig. 3



4. Removing the Recording indicating Lead (from Front Panel)

As the light-emitting diode for indicating recording is mounted on a small-scale P.C board, remove the lead wire at the P.C board.

128 is the red lead wire (on the upper side).

129 is the black lead wire (on the lower side).

\* Use care as LED becomes unusable when error is made in its polarity.

4-1 How to remove pushbutton for switch use

(Cabinet Disassembling Diagrams Nos. 131, 132)

As shown in Fig. 4 (figure at right), this button holds the switch with catches provided on both sides. It will come off when the catch part on one side is widened in the direction of the arrow, while at the same time pushing the (A) part upward and sort of prying the button.

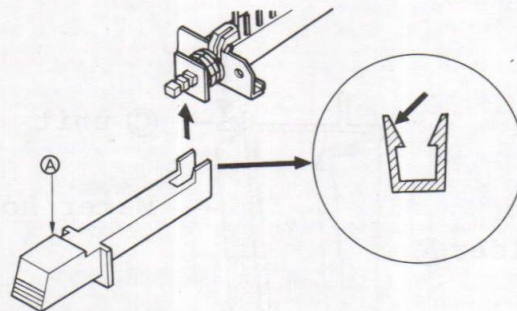

Fig. 4



## 5. Removing the Mechanism Assembly

- 1) Remove the top cabinet cover and the front panel in accordance with the steps presented in 1 and 2.

Note: Remove the front panel when the mechanism unit is to be taken out (it is not necessary to disconnect the wire linking the meter and the recording indicating board).

- 2) Remove screws (1) and (2) shown in Fig. 5. Next, remove holder (A) held in place with screw (1) and remove screw (3) beneath the holder. Then the mechanism assembly can be lifted up.
- 3) Remove the wiring from the mechanism at the base board by pulling the jack out.

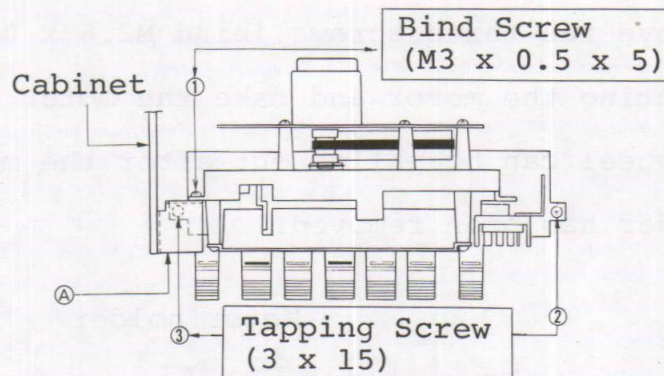

Fig. 5

\* In reassembling:

Refer to the wiring diagram regarding wiring from the mechanism to the base board.



## 6. Removing the Mechanism Parts

Note: In the following, disassembling method subsequent to the state in which the mechanism assembly has been removed in accordance with "5" will be described.

- 1) Removing the motor or the flywheel
  - a. Remove the back tension springs applied to [A], [B] and [C] parts of the motor holder in Fig. 6.
  - b. Remove screws (1) to (4) in Fig. 6 (tapping 3 x 8) and take the motor holder out.
  - c. Untie the binded parts  $\triangle D$  and  $\triangle E$  of the 3 shielded wires (wind the binding wires once so that they will not fall away).
  - d. Remove the two belts applied to the motor pulley.
  - e. Remove the three screws (bind M2.6 x 0.45 x 4) mounting the motor and take the motor out.
  - f. Flywheel can be pulled out after the motor holder has been removed.

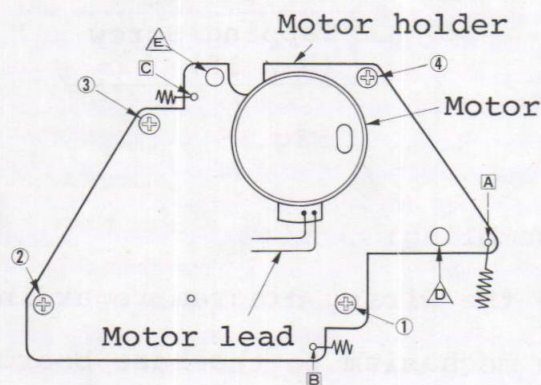

Fig. 6



\* In reassembling:

- When the motor is removed or replaced, mount the lead wires of the motor so that they will be projecting in the direction shown in Fig. 6.
- Mount the belts so that they will not be twisted.

2) Removing the cassette case

- Open the cassette case.
- As the left-hand side tip of the metal lever shown in Fig. 7 protrudes on the back side of the mechanism unit, remove the back tension spring mounted between the metal lever tip and the motor holder (see disassembling diagram No. 71).
- Under the EJECT state, remove screws (1) to (4) (black tapping 3 x 10) on the side of the fixed case shown in Fig. 7.

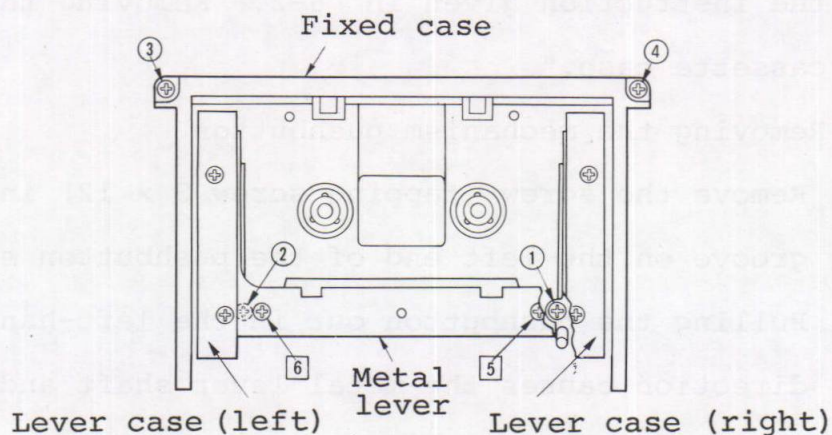

Fig. 7



- d. The lever and the case separate when screws [5] and [6] (M2.6 x 0.45 x 5) fixing the lever case shown in Fig. 7 are removed (if they do not separate easily, insert a (-) screw driver or like in between and pry them apart).
- e. As a little metal lever is holding up the case from being pulled out at the back of the mechanism unit, move the metal lever inward when removing the lever case from the main unit.

\* In reassembling:

- Have the fixed case set in when lever case is to be set into the mechanism unit.
- As the metal lever obstructs entry of the lever case, as in the case of removing it, move the metal lever inward when the lever case is to be set.

### 3) Removing the pinch lever

The pinch lever can be taken out by following the instruction given in "6-2. Removing the cassette case."

### 4) Removing the mechanism pushbutton

- a. Remove the screw (tapping screw 3 x 12) in the groove on the left end of the pushbutton shaft.
- b. Pulling the pushbutton out in the left-hand direction causes the metal lever shaft and the pushbutton shaft shown in Fig. 7 to become removable. Then the STOP, FF, PLAY and REC buttons can be pulled out.



c. The EJECT pushbutton can be taken off by removing the pulling spring. The REC pushbutton can be taken off by moving the erroneous erasing preventing lever and pushing out the REC link with the REC pushbutton.

In case the PAUSE pushbutton is to be removed, first remove the flywheel in the manner described in 6-1 and remove fixing screws (tapping 3 x 8) of the PAUSE mechanism (back of the mechanism unit). Then

- remove E ring (E2.5) holding down the pinch lever on the top of the mechanism unit and remove the pinch lever;
- remove the back tension spring of the PAUSE pushbutton on the link side;
- Remove the link by sliding the PAUSE link shown in Fig. 8 upward and then remove the PAUSE pushbutton.

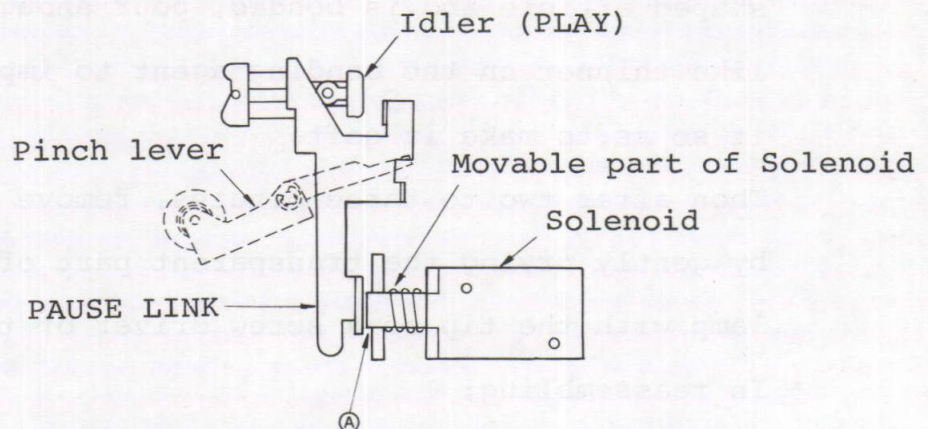

Fig. 8



\* In reassembling:

- The PAUSE link is assembled in as shown in Fig. 8 after assembling the PAUSE pushbutton, but use care as the movable rod of the solenoid obstructs insertion of the link at (A) in Fig. 8.
- As a torsion spring that returns the button to its original position is provided beneath the groove into which the button is inserted, insert the STOP button so that the spring will be on the top side of the STOP button lever.
- In inserting the REC pushbutton, couple the lever part with the link mover and the link depression.

5) How to remove the lamp (for illuminating the balance of tape)

As the lamp is inserted into the groove of the shaped article and is bonded, pour enough solvent like thinner on the bonding agent to impregnate it so as to make it soft.

Then after two to three minutes, remove the lamp by gently prying the transparent part of the lamp with the tip of a screw driver or the like.

\* In reassembling:

- Use a small amount of bonding agent to lock the lamp after it has been inserted completely into the groove.



- 6) Removing the idler (PLAY) (Mechanism disassembling diagram No. 14)

The idler can be removed if the flywheel is removed in accordance with 6-1.

7)

Parts to be Removed	Mechanism Diagram No.	Reference Range
Reel rest	Supply side 10 Take-up side 11	a - j
Pulley (fast forward)	13	a - i
Idler (FF)	12	a - h
Lever (back tension)	43	
Pinch lever assembly	28	a

- (a) Remove the cassette case according to "6-2".

The pinch lever assembly lever (back tension) can be removed by the steps given in (a).

The lever (back tension) can be taken out if the felt part shown in Fig. 9 is turned in the direction shown by the arrow and is lifted up from the shaped part of (A).

\* In reassembling,

the position of mounting the spring (back tension) is as shown in Fig. 9.

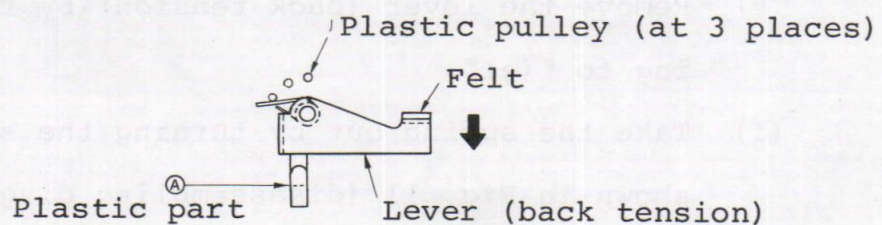

Fig. 9



- (b) Remove the flywheel in accordance with "6-1".
- Remove the springs below the flywheel (from the back side) at (A), (B) and (C) shown in Fig. 10.
  - As a separate spring is provided in D below the spring that has been taken off at (B), remove it at D.

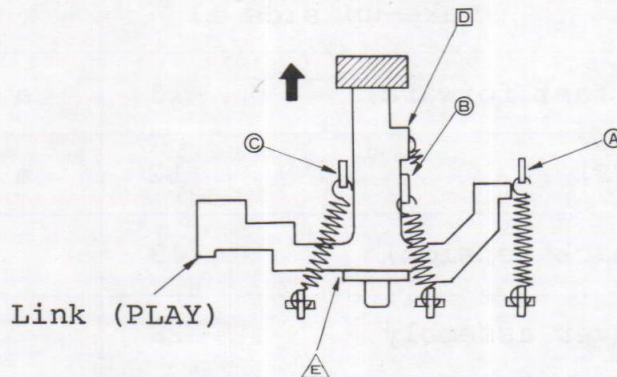

Fig. 10

- (c) After removing the 4 springs in (b), remove E by pushing the link (PLAY) shown in Fig. 10 in the direction of the arrow and then remove the link (PLAY).
- (d) Next, placing the mechanism as the front side, remove the pinch lever assembly and the main plate (disassembling diagram Nos. 28 and 5).

At this time use care not to lose the steel balls found in three places (refer to disassembling diagram No. 52).

- (e) Remove the lever (back tension) by referring to "(a)".
- (f) Take the spring out by turning the spring shown in Fig. 11 (disassembling diagram No. 64) in the direction shown by the arrow.



- (g) Remove the links (A) and (B) shown in Fig.11 (disassembling diagram Nos. 44, 45) by pushing them up in the direction shown by the arrow.
- (h) Remove the idler assembly (FF) (disassembling diagram No. 13)  
 Draw it out by making (A) shown in Fig. 12 bend in the direction shown by the arrow.
- (i) Removing of the idler assembly (PLAY) in accordance with (h) makes it possible to remove the pulley assembly (FF) shown in Fig. 11.

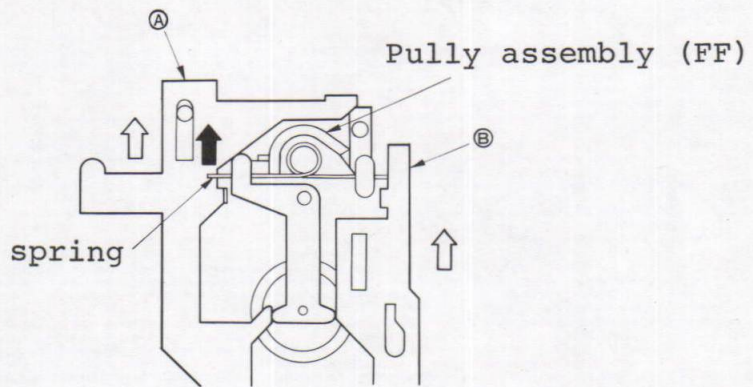

Fig. 11

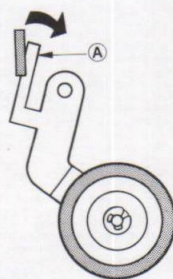

Fig. 12



(j) Removing the reel rest holder

It can be removed by sticking the finger tip below the cap (disassembling diagram No. 85) and prying it. And when E ring (E1.5) is subsequently removed, the reel rest holder will come off.

\* In reassembling:

- Set the counter belt on the taking-up reel rest.
- Be careful not to let the E ring (E1.5) fly off when assembling it in.
- Take care not to forget to put a washer (disassembling diagram No. 84) under E ring.



## ADJUSTMENT OF THE MECHANICAL UNIT

1. Mount the solenoid on the side of the movable shaft.
2. In measuring the pinch lever pressure, place the tip of the tension gauge at right angle to the direction that links the capstan shaft and the pinch roller shaft.

(Refer to section on mechanical performance:

330g  $\pm$  50g)

3. Refer to Fig. 9 for setting the spring position of the back-tension lever.
4. For measuring the winding torque, use either a winding torque measuring cassette or the hub of an old cassette and take measurement with the value derived by multiplying the radius with the measure value. Also, measure it with a torque dial guage (see Fig. 13).

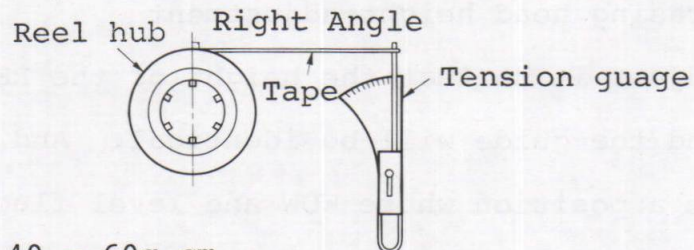

PLAY 40 - 60g.cm

FF.REW 90 - 150g.cm

Fig. 13



5. Tape speed adjustment

Play the 3kHz test tape MTT-11 and adjust the speed so that it will be within the range of  $3000\text{Hz} \pm 60\text{Hz}$ . (see Fig. 14).

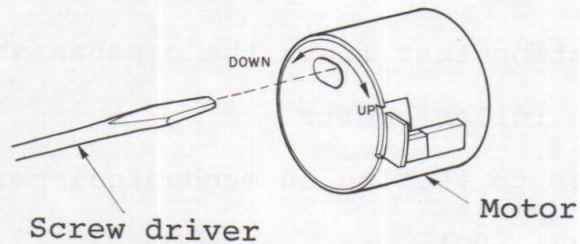

Fig. 14

6. Head angle adjustment

In case the REC/PLAY head has been replaced or it has been operated at a wrong angle, use test tapes MTT-115 (333/6.3kHz) and MTT-115C (330/10kHz) and set the position so that the playing output of the higher frequency will be at maximum (after completing adjustment apply screw lock).

7. Erasing head height adjustment

Adjust it so that the height of the REC/PLAY head and the guide will be identical. And also fix it at a position where WOW and level fluctuation will be minimized.

Use MTT-111 (3kHz) tape for measuring WOW.

- o Refer to the section on "Performance" for the value of WOW. Playing method 0.18rms (auditory feeling compensating value under the playing method is 0.07rms).



## ELECTRICAL ADJUSTMENT

■ Undertake adjustment when necessary after parts replacement and so forth.

● Instruments Used

- 1) Low-frequency oscillator: 20Hz - 20kHz
- 2) Variable resistance attenuator: 0 - 90dB  
or 0.1 or 0.5dB  
step
- 3) AC voltmeter: 20Hz - 100kHz or more,  
input impedance of 100k $\Omega$   
or more, capable of  
measuring down to -60dB(V)
- 4) Vacuum tube voltmeter: for DC voltage measurement
- 5) Frequency counter
- 6) Oscilloscope
- 7) Test tapes

● Output Unit Connection

For each of L and R channels connect a 22k $\Omega$  resistor as shown in Fig. 15 and undertake adjustment (the reason is to make the output level proper).

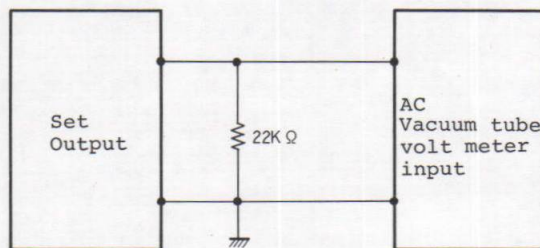

Fig. 15



- Unless otherwise specified, leave TAPE SELECT on the NORMAL side and DOLBY NR on the OUT side during adjustment.

#### Selection of AC Power Source (Primary Side)

When AC power source is 240 V, be sure to use the voltage selector attached to this set in harmony with specified 240 V.

Voltage Selector

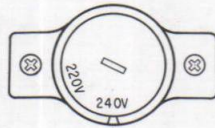

Set the voltage to the position having a cavity.

Fig. 16



\* Adjustment of Printed Circuit Board

- When each volume control is turned in the direction of the arrow the arrow of the printed circuit board, the signal (or current) increases.
- In case DOLBY NR is used, it is indicated as DOLBY NR "IN".
- In adjusting the REC/PLAY system, work will be easier if adjustment began after centering the various volume controls (VR104, VR204, VR501, VR502).

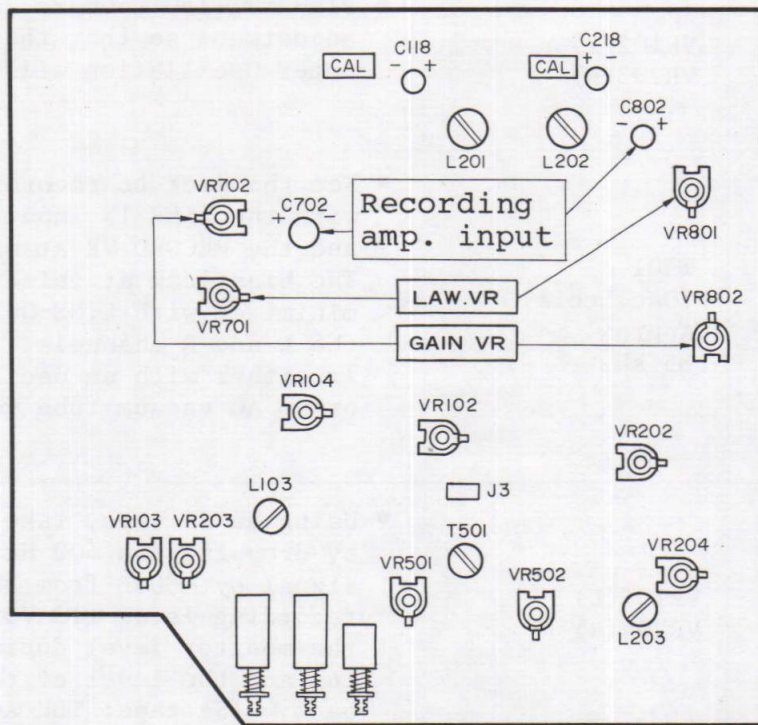

Fig. 17



ADJUSTMENT

	Adjusting Point	Adjusting Method
Playing Output	VR102(L) VR202(R)	<p>Playing MTT-150 (test tape)</p> <ul style="list-style-type: none"> <li>● Set it at 580mV <math>\pm 0.25</math>dB at CAL point between (-) side of C118 and C218 and the earth.</li> </ul> <p>Remarks: If any adjustment error should be made at CAL point the error will double in its effect when REC/PLAY is made at DOLBY "IN". This requires correct adjustment.</p>
Meter Sensitive	VR102(L) VR203(R)	<ul style="list-style-type: none"> <li>● Play MTT-150 (400 Hz) and make adjustment so that the deck level meter Oscillation will be +3 VU.</li> </ul>
Bias Leak	T501 (Osc. coil) Approx. 85 kHz	<ul style="list-style-type: none"> <li>● Set the deck to recording state with the LINE IN input at zero and the RECORD VR at maximum. The bias leak at this time is minimized with LINE OUT both for the L and R channels. Observe it either with an oscilloscope or an AC vacuum tube voltmeter.</li> </ul>
REC/PLAY Output	VR104(L) VR204(R)	<ul style="list-style-type: none"> <li>● Using an SA tape, take recording by dropping the 400 Hz recording signal by -30dB from the regular recording level (+3 VU) and match the monitor level during recording and the level of the playback. (SA tape: TDK AC-511).</li> </ul>
Recording Frequencies Response	VR501(L) VR502(R) (See Note 1)  L103(L) L203(R)	<ul style="list-style-type: none"> <li>● Record and play the frequency of 6.3 kHz under the same conditions as given in "REC/PLAY Output" and match the output with that with that of REC/PLAY Level of the 400 Hz of "REC/PLAY Output". (See Note 1)</li> <li>● Repeat the same procedure with 12.5 kHz.</li> </ul>



	Adjusting Point	Adjusting Method
MPX Filter	L102(L) L202(R)	<ul style="list-style-type: none"> <li>● Set the deck to recording state and stop BIAS oscillation (remove J3 and short-circuit between terminals 1 and 3). Apply 19 kHz <math>\pm 1\%</math> signal to LINE IN. Under this state make adjustment so as to minimize the LINE OUT output.</li> </ul>
Dolby Circuit	<ul style="list-style-type: none"> <li>● GAIN VR VR702(L) VR802(R)</li> <li>● LAW VR VR701(L) VR801(R)</li> <li>● Detecting point CAL point Between (-) side and earth of C118(L), C218(R)</li> <li>● Detecting point Between (-) side and the earth of recording amplifier input C702(L), C802(R).</li> </ul>	<ul style="list-style-type: none"> <li>● Set the frequency at 5 kHz under the "MPX Filter" state (stop bias oscillation).</li> <li>● Set the Dolby switch (S105) to the OUT side.</li> <li>● Have both GAIN VR and LAW VR in the direction counter to that shown by the arrows.</li> <li>● Have the gates (terminal G) of FETs (Q703 for L, Q803 for R) grounded.</li> <li>● Next, make adjustment with LINE input or RECORD LEVEL (main) VR so that the "CAL Point" output will be 17.5 mV.</li> <li>● Adjust "GAIN VR" so that it will rise 10 dB <math>\pm 0.25</math>, when the Dolby switch is changed over to IN side while observing the recording amplifier input.</li> <li>● Next, detach the earth from the terminal G or FET and adjust "LAW VR" so that it will drop 2 dB <math>\pm 0.25</math>.</li> </ul> <p>Upon completion of the foregoing adjustments, remove the short-circuiting between terminals 1 and 3 made under "MPX Filter" and insert J3 terminal. This completes adjustment.</p>



[Note 1] The recording equalizer characteristics are shown in Fig. 18.

Recording Equalizer Characteristics

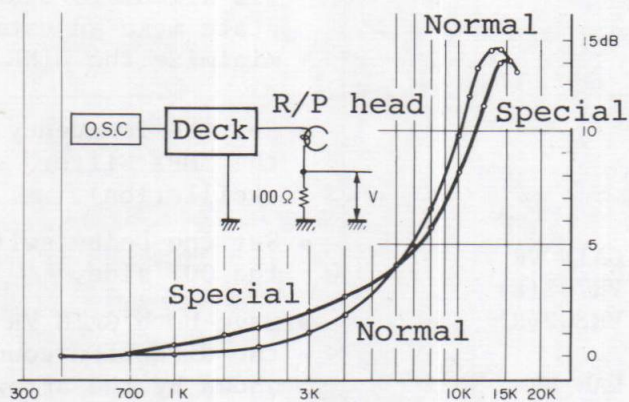
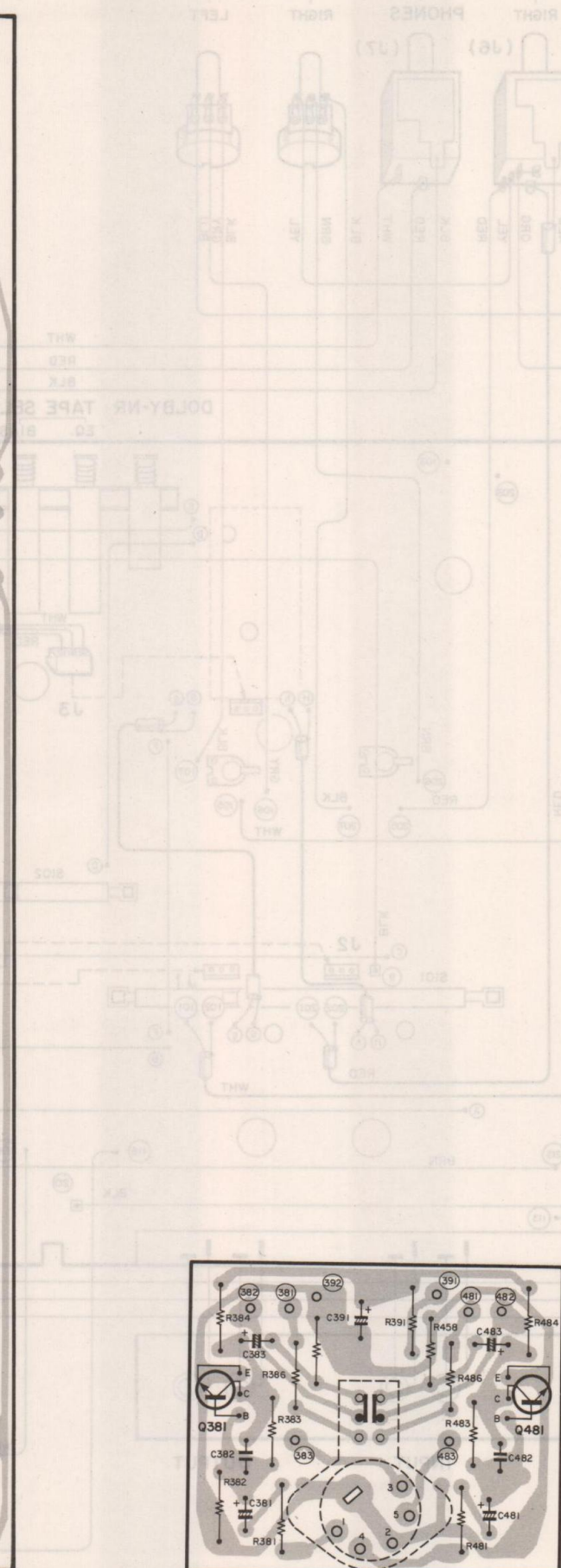
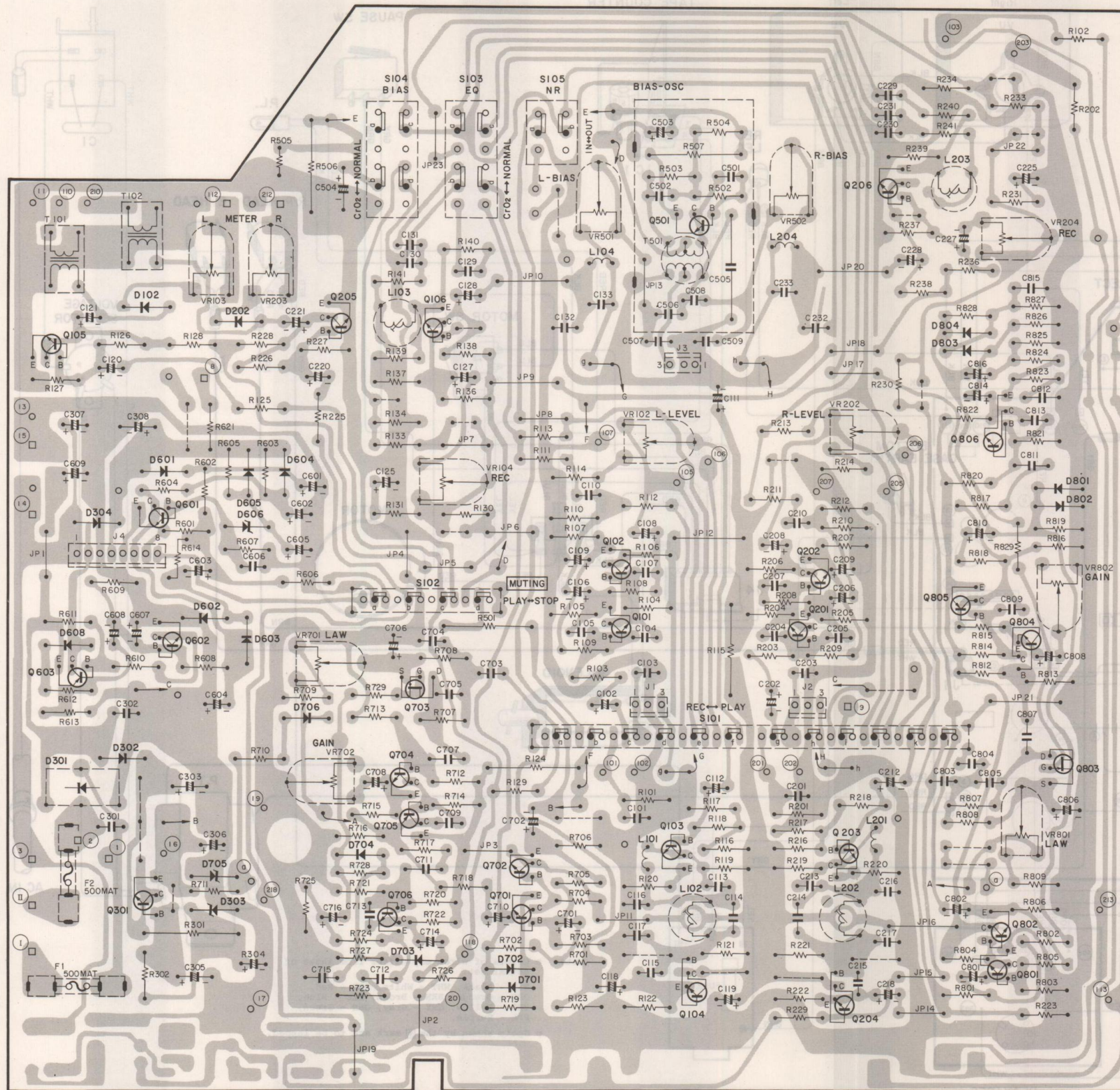
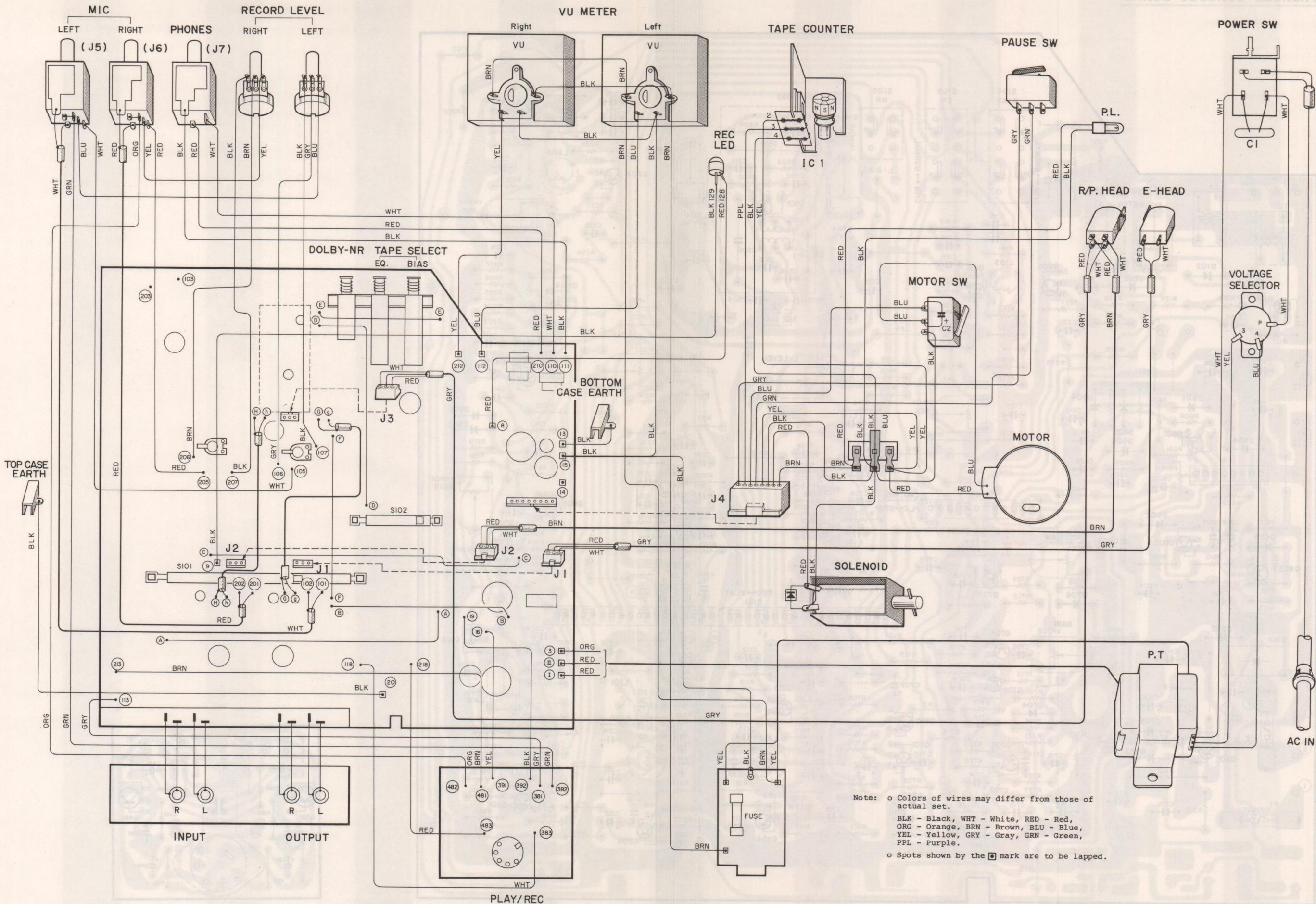

Fig. 18









Note: ○ Colors of wires may differ from those of actual set.  
 BLK - Black, WHT - White, RED - Red,  
 ORG - Orange, BRN - Brown, BLU - Blue,  
 YEL - Yellow, GRY - Gray, GRN - Green,  
 PPL - Purple.  
 □ Spots shown by the mark are to be lapped.



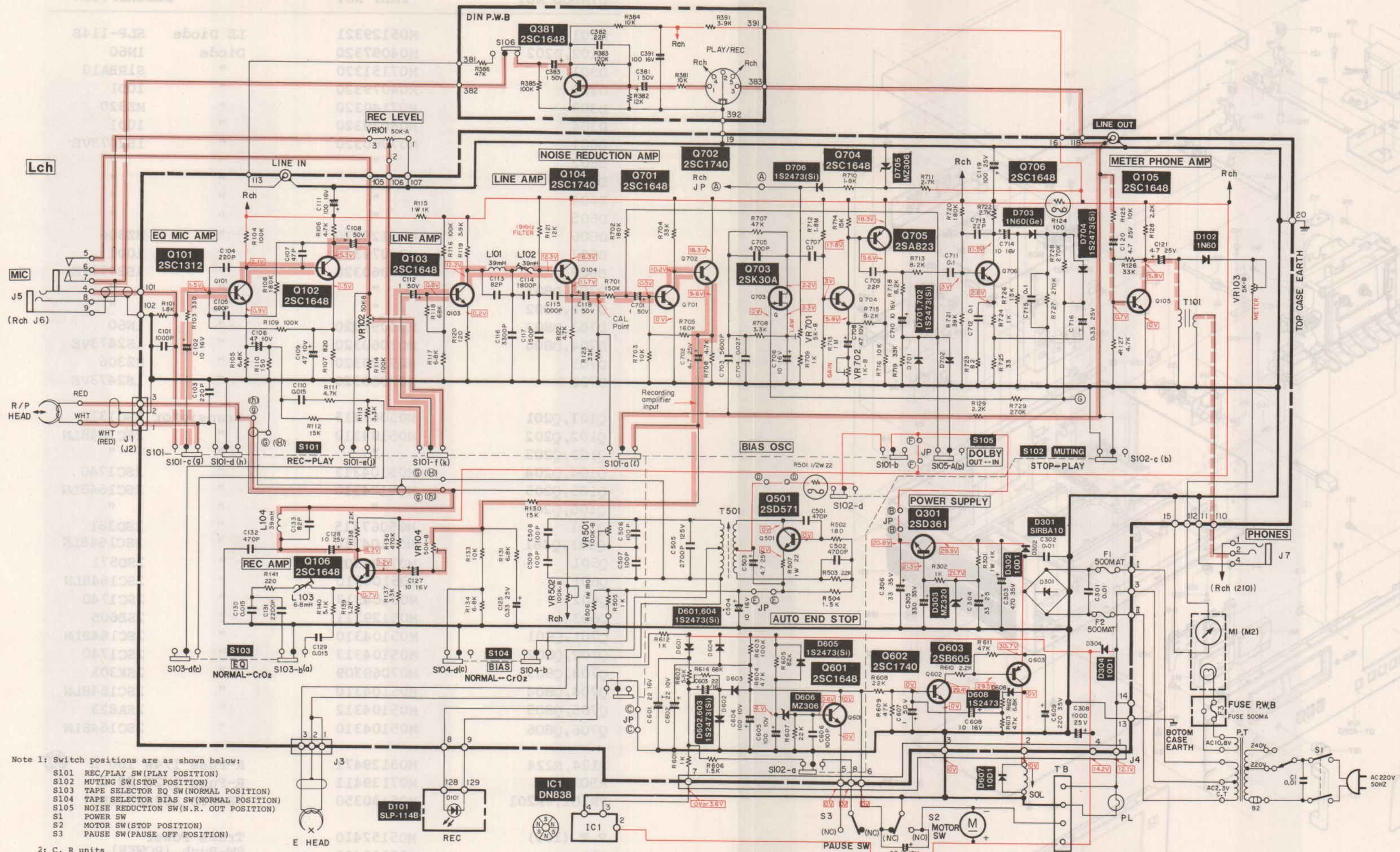

Note 1: Switch positions are as shown below:

- S101 REC/PLAY SW (PLAY POSITION)
- S102 MUTING SW (STOP POSITION)
- S103 TAPE SELECTOR EQ SW (NORMAL POSITION)
- S104 TAPE SELECTOR BIAS SW (NORMAL POSITION)
- S105 NOISE REDUCTION SW (N.R. OUT POSITION)
- S1 POWER SW
- S2 MOTOR SW (STOP POSITION)
- S3 PAUSE SW (PAUSE OFF POSITION)

2: C, R units  
 (1) C - no code  $\mu$ F (2) R - no code  $\Omega$   
 p code pF K code K $\Omega$

3: Resistors not specified are all 1/4W carbon resistors.

4: Legend number of Rch (omitted) are 200 and 800. Figures in ( ) also indicate Rch.

5: The voltages of the various parts are values measured with DC 20 K $\Omega$ /V tester.

6: As the parts marked  $\text{\textcircled{R}}$  have an effect on safety, be sure to use identical parts when replacing them (be careful of an increasing resistance).

These are basic circuits, and their constants may be changed on account of improvements and so forth.

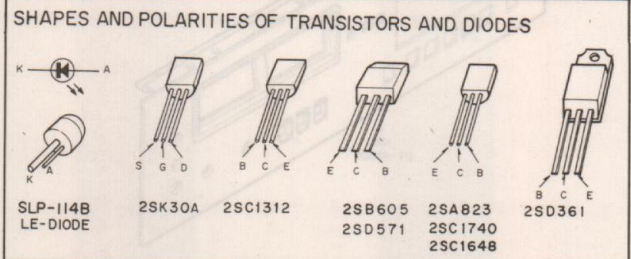
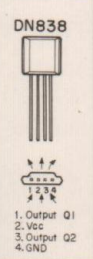
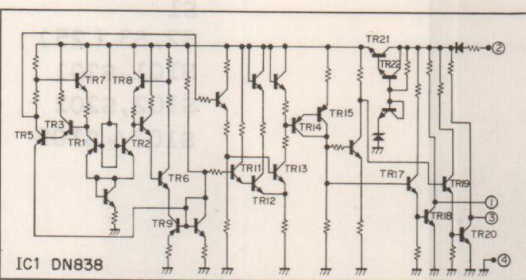
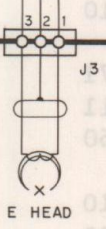



EXPLODED DIAGRAM OF CABINET

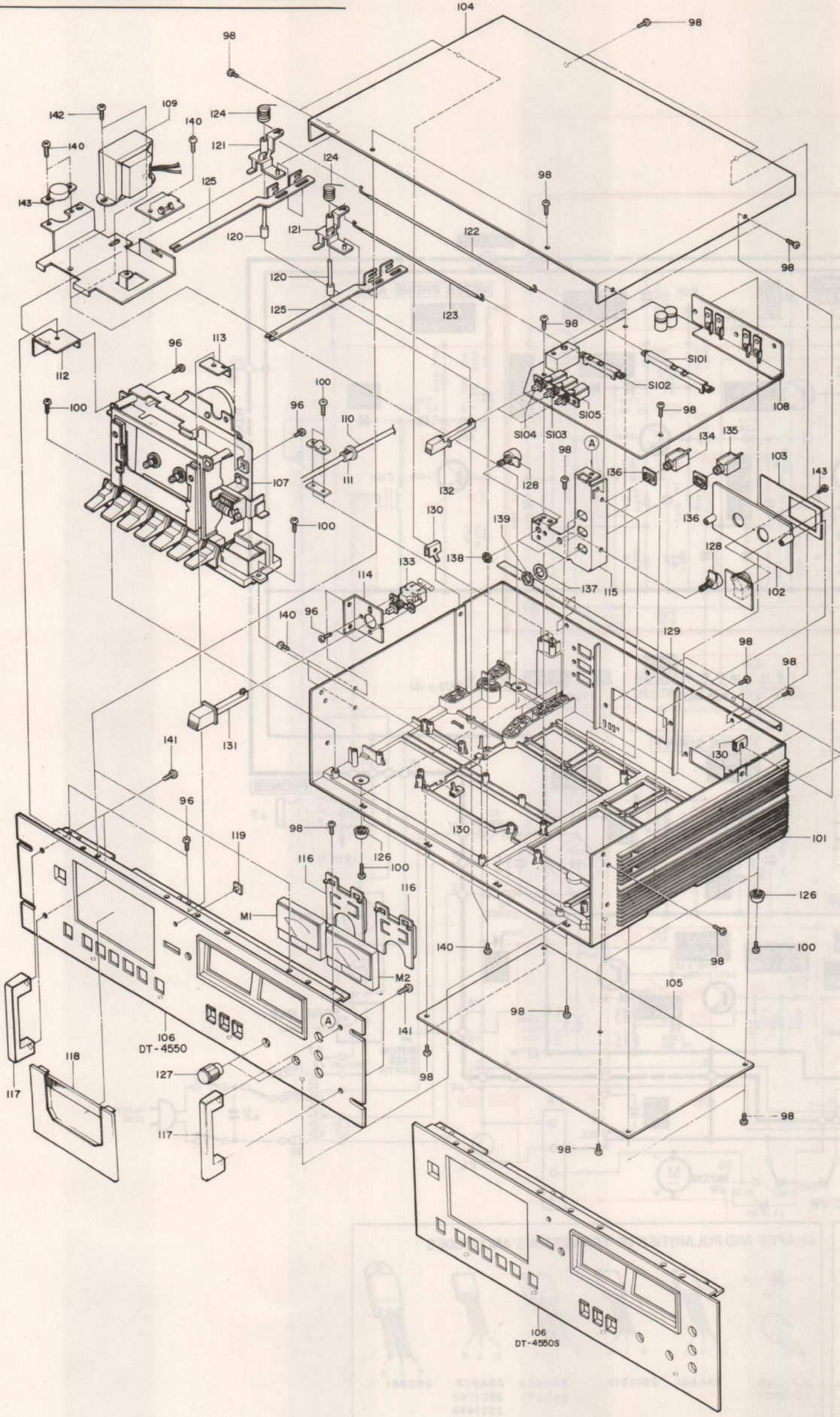

PARTS LIST

SYMBOL NO.	PART NO.	DESCRIPTION
D101	M05129321	LE Diode SLP-114B
D102, D202	M04097320	Diode 1N60
D301	M07151320	" 1SRBA10
D302	M04079320	" 10D1
D303	M07140320	" MZ320
D304	M04079320	" 10D1
D601	M07060320	" 1S2473VE
D602	"	" "
D603	"	" "
D604	"	" "
D605	"	" "
D606	M05129320	" MZ306
D607	M04079320	" 10D1
D608	M07060320	" 1S2473VE
D701, D801	"	" "
D702, D802	"	" "
D703, D803	M04097320	" 1N60
D704, D804	M07060320	" 1S2473VE
D705	M05129320	" MZ306
D706	M07060320	" 1S2473VE
Q101, Q201	M05067313	Transistor 2SC1312
Q102, Q202	M05104310	" 2SC1648LN
Q103, Q203	"	" "
Q104, Q204	M05104313	" 2SC1740
Q105, Q205	M05104310	" 2SC1648LN
Q106, Q206	"	" "
Q301	M05067315	" 2SD361
Q381, Q481	M05104310	" 2SC1648LN
Q501	M07228303	" 2SD571
Q601	M05104310	" 2SC1648LN
Q602	M05104313	" 2SC1740
Q603	M05129311	" 2SB605
Q701, Q801	M05104310	" 2SC1648LN
Q702, Q802	M05104313	" 2SC1740
Q703, Q803	M07068309	" 2SK30A
Q704, Q804	M05104310	" 2SC1648LN
Q705, Q805	M05104312	" 2SA823
Q706, Q806	M05104310	" 2SC1648LN
R124, R224	M05129471	R-Fuse 1/4W 100 Ω
R501	M07139411	R-Fuse 1/2W 22 Ω
VR101, VR201	M05130350	VR-STD A50K25 (REC)
P.T (109)	M05152410	Trans Power
S1	M05113430	SW-Push (POWER)
S2, S3 ( 25 )	M05129431	SW Micro
S101, S201	M05130430	SW-Slide (REC/PLAY)
S102, S202	M05085435	" (MUTING)
S103 ~ S105	M05130431	SW-Push



SYMBOL NO.	PART NO.	DESCRIPTION
J5,J6 (134)	M05129447	Jack (MIC)
J7 (135)	M05104441	" (HEAD-PHONE)
M1,M2	M05130400	Meter
F1,F2	M07337490	Fuse 500MAT SEMKO
F3	M07337490	Fuse 500MA SEMKO



# EXPLODED DIAGRAM OF MECHANICAL PARTS

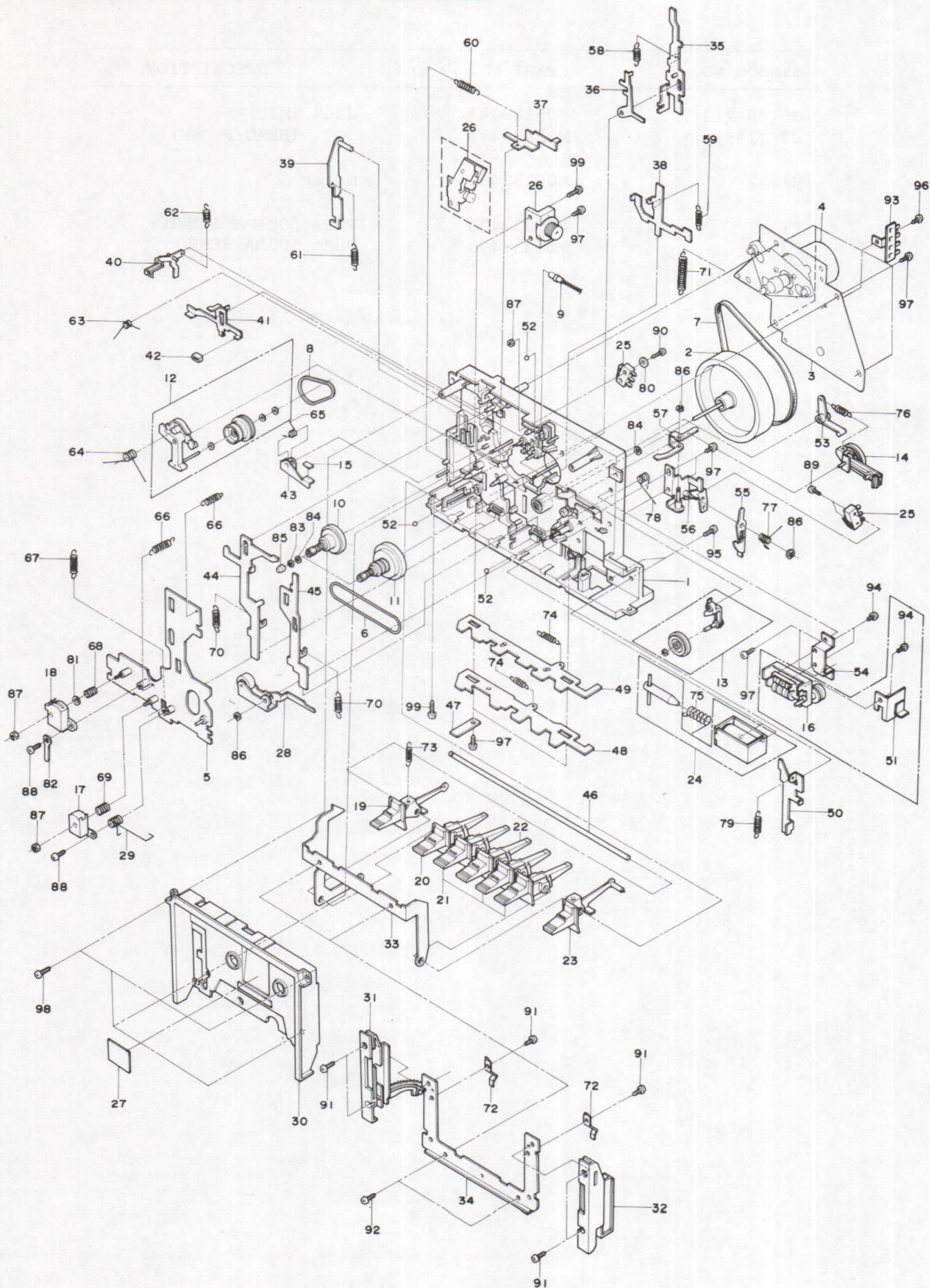



EXPLODED DIA. NO.	PART NO.	DESCRIPTION
2	M05104520	Flywheel
3,4	M05129501	Motor Ass'y
6	M05129551	Belt (COUNTER)
7	M05104551	" (MOTOR)
8	M05129552	" (FF.REW)
9	M05131490	Lamp
10	M05129525	Reel Rest (SUPPLY)
11	M05129526	" (TAKE-UP)
12	M05129540	Pulley Ass'y (FF/RWD)
13	M05129541	" (FF)
14	M05129542	" (PLAY)
16	M05129404	Counter (IC1)
17	M05111830	Head (REC/PLAY)
18	M05104831	" (ERASE)
24	M05129390	Solenoid
26	M05129620	Gear Ass'y (DAMP)
27	M05129544	Pinch Lever Ass'y
118	M05348111	Cover Ass'y
127	M07229212	VR Knob (REC LEVEL)
131	M07228212	Knob (POWER)
132	M07228211	" (BIAS/EQ/DOLBY)
	M07050470	Lead (L+R for Connection Cord)



